

Applications

DD simple yoke pulleys are return pulleys for rope dedicated to slow applications. They permit lifting or rope deviation - without limit on use height or distance

They can be suspended to a fixed or mobile anchorage point with the right strength corresponding to the required load.

DD pulleys are fitted with a swivel hook which ensures good positioning of the pulley regarding the rope.

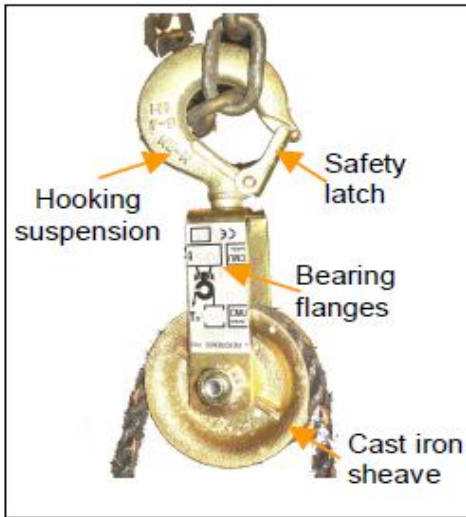

Description

A hook with safety latch is installed on the DD pulleys to ensure a quick and safe attachment.

DD pulley is a non opening block: rope is installed by pulling one of its end between bearing flanges. Important height of bearing flanges permits easy installation of the rope and ensures space for splice.

The cast iron sheave is rotation free.

Dimensional characteristics

WLL* on suspension kg	WLL* on a leg kg	Rope Ø		Sheave ext. Ø	Bottom of groove Ø	Groove Ø	Hook bowl to top	Overall width	Weight kg	Ref.
		min	max	E	F	G	H			
250	125	15	17	80	63	18	191	55	0,8	D040D
500	250	17	19	100	80	20	236	65	1,8	D042D
1000	500	23	25	160	131	25	68	76	3,4	D046D

* Working Load Limit

Dimensions en mm

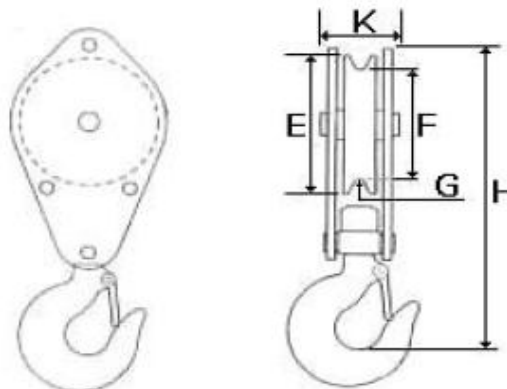

Technical characteristics

- Ultimate load is 4 times the working load limit (WLL).
- Zinc bichromated coating.

Non-conform uses

- NEVER USE FOR PERSONNEL LIFTING.
- Always use suitable rope (size, length and capacity)
- Strictly forbidden to either be under or to walk under the load.
- The block should be regularly inspected (pquiry checking: parts correctly assembled, no excessive movement, no excessive wearing or corrosion, no deformation, no weld corrosion or cracking, free rotating sheave).
- Prior to using the block, check for proper position and locking of the snatch block.
- Never use a block with a hook as headfitting without ensuring that the safety latch is correctly operated and free from deformation.
- For lifting operations, the user must refer to the safety rules and regulations applicable to this issue.
- The operator is not authorised to release the rope or leave equipments out of control when a load is hanged up on a pulley.
- Never install a Charlet return pulley as a hook block on lifting equipments (crane, hoist, ...).

Calculation of loading of a snatch blocks

The maximum Working Load Limit (WLL) written on the side of the block is the maximum load that should be exerted on the block and its connecting fitting.

This total load value F varies with the angle (α) between the incoming and departing lines to the block. The following table indicates the factor to be multiplied by the line pull to obtain the total load F on the block.

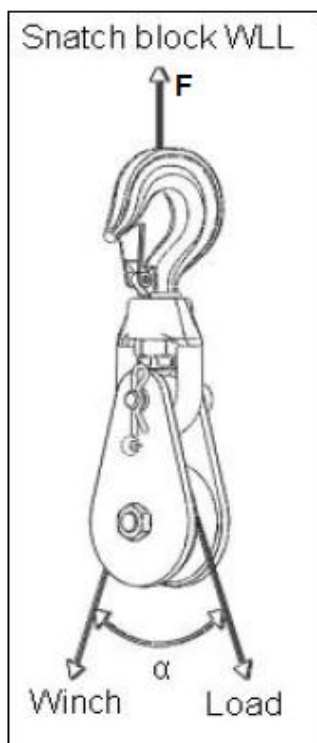

Angle α	Effort applied on suspension "F"
0°	winch WLL x 2
15°	winch WLL x 1,98
30°	winch WLL x 1,95
45°	winch WLL x 1,85
60°	winch WLL x 1,73
90°	winch WLL x 1,41
120°	winch WLL x 1
150°	winch WLL x 0,52
180°	winch WLL x 0

Always ensure :
F < pulley WLL
F < anchoring point resistance.