

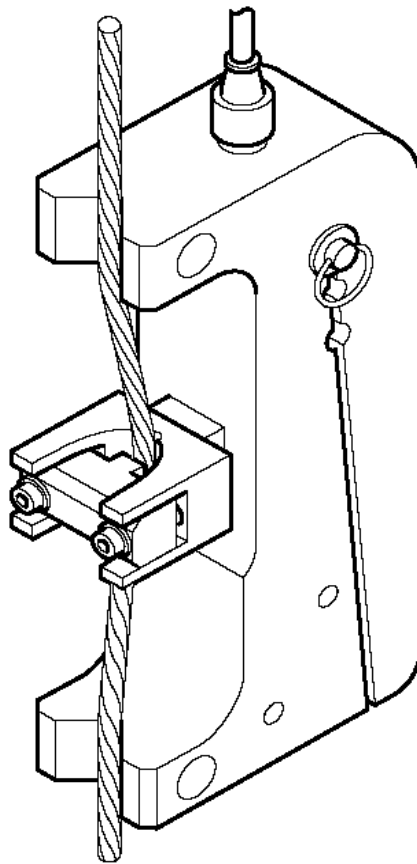

HF 32/3/A Universal load cell

Including wiring for 2 trip points



**Operating
and
maintenance
manual**

GENERAL WARNING	2
INSTALLATION OF HF 32 LOAD CELL	3 – 4 - 5
OPERATION AND ADJUSTMENT OF HF 32 LOAD CELL	6
WIRING OF HF 32 TWO TRIP POINTS	7

GENERAL WARNING

- 1- Reading and fully understanding the technical data sheets relating to this equipment is essential for the best use of this high technological material that you have received . All the technical data sheets are available on request.
- 2- Before installing and operating Dynasafe equipment it is essential for the safe and correct operation of the material that this manual be read and fully understood and that all the instructions be followed. This manual should be made available to every operator. Extra copies of this manual will be supplied on request.
- 3- The installation and the operation Dynasafe equipment should only be carried out in accordance with the appropriate health and safety at work regulations.
- 4- Never apply to the Dynasafe a load or an effort in excess of the working load limit, and never use it for an operation for which it is not intended.
- 5- TRACTEL S.A.S declines any responsibility for the consequences of dismantling or altering the machine by any unauthorized person.
- 6- Dynasafe equipment must not be used in explosive atmospheres.
- 7- Dynasafe equipment must only be used in a system designed for lifting people after ensuring that the appropriate operating coefficients have be used in accordance with the current regulations.
- 8- Prior to the use of Dynasafe equipment with complementary equipment relaying the signals to an operating system, the user or installer of this system should carry out a specific risk analysis of the operating functions. The appropriate measures should be taken to obviate risks identified.

INSTALLATION OF HF 32/3/A LOAD CELL

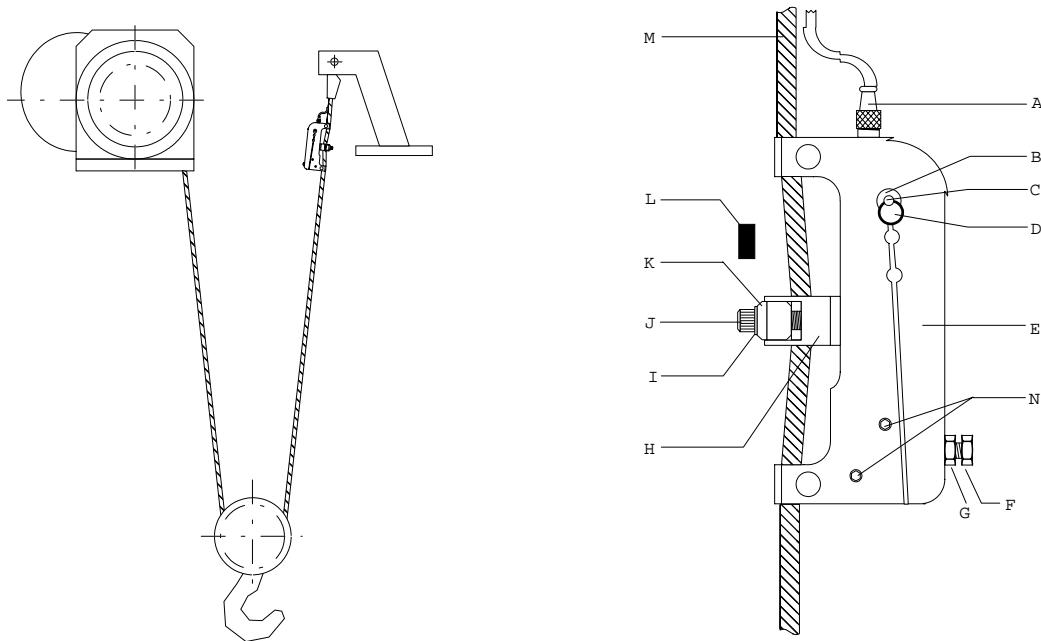

Fig. 1

Components of the load cell

A- 2 m connecting cable	F- Tare screw.	K-Tightening bracket.
B- Flat washer.	G- Locking nut	L-Rubber compression pad.
C- Adjusting pin.	H-Traction part.	M-Wire rope.
D- Locking ring.	I- Safety washer.	N- Fixing screws for circuit
E- Load cell body.	J- Tightening screw.	breaker.(do not touch)

Procedure for installing load cell

Essential condition : the hook of the lifting system should be free of any load.

- Position the adjusting pin as a function of the load range and wire rope diameter (see p. 4).
- Remove the tightening bracket (K).
- Position the load cell on the wire rope near the dead end/fixed point. The connecting cable should be uppermost.
- Replace the tightening bracket (K) ensuring that it is correctly positioned depending on the diameter of the wire rope. (See page 4)
- Adjust the tightening screws (J) symmetrically (+/- 0.5 kgm) to ensure that there is no risk of moving the load cell out of line with the wire rope. Excessive tightening may break the bracket.
- Operate the lifting system up to the upper limit switch and ensure that the sheaving or bottom block does not foul the load cell. If this happens adjust the upper limit switch so that there is an appropriate distance between the load cell and the bottom block. Also check that when the bottom block is in the upper position the load cell is not in contact with the overhead crane.
- Wire the connecting cable from the load cell to the control box. Ensure that the cable is secured.

INSTALLATION OF HF 32/3/A LOAD CELL

Positioning the adjusting pin as a function of the effort in the wire rope

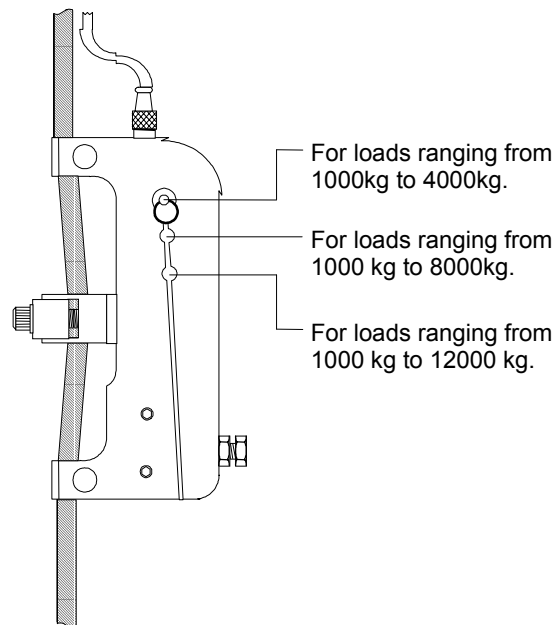

Pinçage du capteur sur le câble

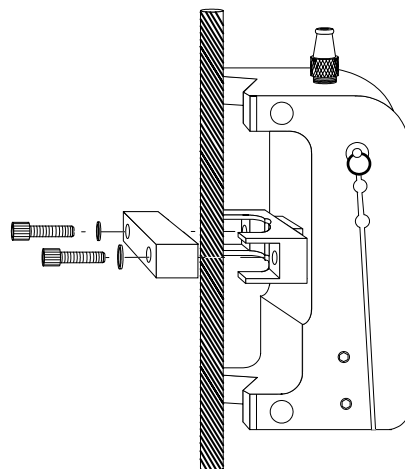

Fig. 2

Important remarks

- Before loading and if no preadjustment has been made in the factory, unscrew the adjustment screw at the most, because you risk to destroy the transducer.
- To select pin and bracket position, load has priority over wire rope diameter.
- Never remove the locking nut (G) because tare screw (F) could damage the microswitch.

OPERATION AND ADJUSTMENT OF HF 32/3/A LOAD CELL

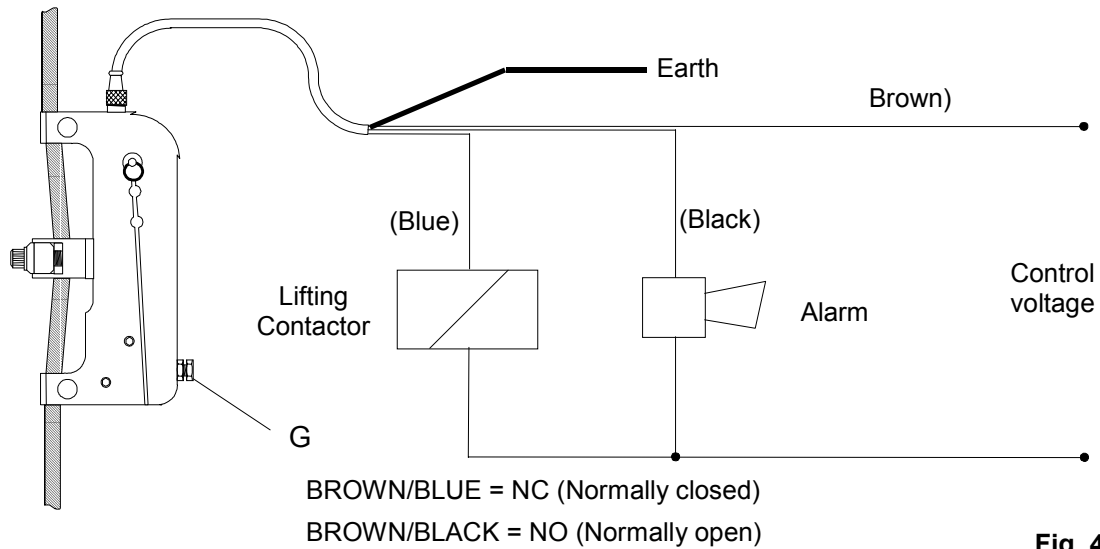

Fig. 4

The switching power is 4A, 220 Vac (0.3A, 250 Vdc). (It is therefore possible to connect in series in the upper limit switch circuit).

Adjustment of the safety trip point

- Essential conditions :
- The load cell must be correctly installed and wired.
 - The hook of the lifting system should be free of any load.
- Equipment required :
- A load ("Pm") equivalent to 100 % of the working load limit of the lifting system .
 - An additional load equivalent to 10 % of « Pm ».

	ACTION	EXPLANATION
1	Lift the two loads (100% + 10% of Pm) by +/- 10 cm.	The additional 10 % load represents the overload value permitted under the European directives. If an overload situation is detected in the wire rope (without lifting the loads) the preadjustment of the load cell in the factory is too low for your lifting system. Solution: release the tare screw (F - see fig. 4) one turn at a time and restart at the beginning of point 1.
2	To adjust the safety trip point.	Use the tare screw (F). <u>Warning : incorrect adjustment may damage the circuit – breaker.</u> Do not forget the locking nut (G). The switch is a normally closed contact (NC), requiring the opening of the switch to set off an overload condition. Turn clockwise to reduce the value of the trip point. Turn anticlockwise to increase the value of the trip point

INSTALLATION OF HF 32 / . / A . TWO TRIP POINTS

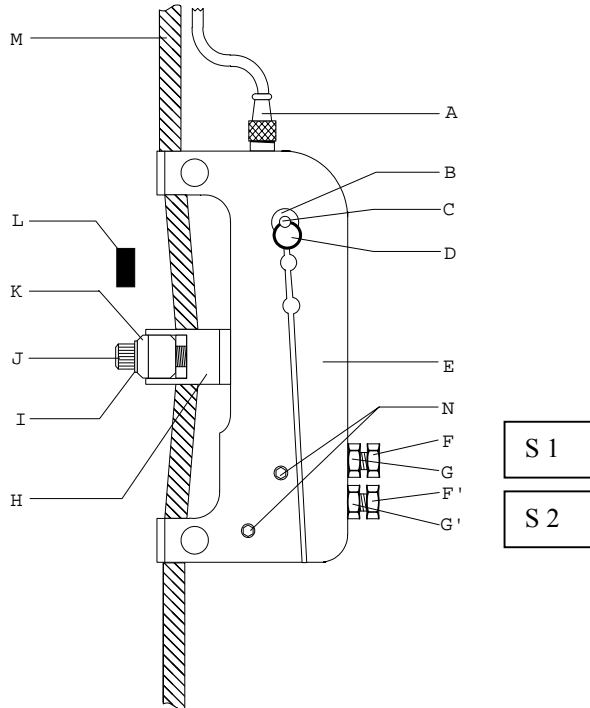

Components of the load cell

- A – Cable connection.
- B – Flat washer.
- C – Adjust pin.
- D – Locking ring
- E – Load cell body.
- F – Tare screw for trip point N° 1.
- G – Locking nut for trip N° 1.
- F' - Tare screw for trip point N° 2.
- G' - Locking nut for trip N° 2.
- H –Traction part.
- I – Safety washer.
- J – Tightening screw.
- K – Tightening bracket.
- L – Rubber compression pad.
- M – Wire rope.
- N – Fixing screws for circuit-breaker.

The individual adjustment of each trip point must be carried out as explained in this manual for the one trip point models.

WIRING

Trip point 1(intermediary)

GREEN / BROWN : NC (4 A 220 Vac)
 WHITE/ BROWN : NO (4 A 220 Vac)

Trip point 2 (Safety)

BLUE / GREY : NC (4 A 220 Vac)
 PINK / GREY : NO (4 A 220 Vac)

NOTES :